

ELECTRICAL POWER SUPPLY: 24 [Vdc]
 CONNECTOR M8 MALE 3 POLES:
 PIN 1(BROWN): +24 Vdc
 PIN 3(BLUE): 0 Vdc
 PIN 4(BLACK): NOT CONNECTED

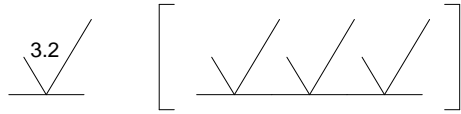
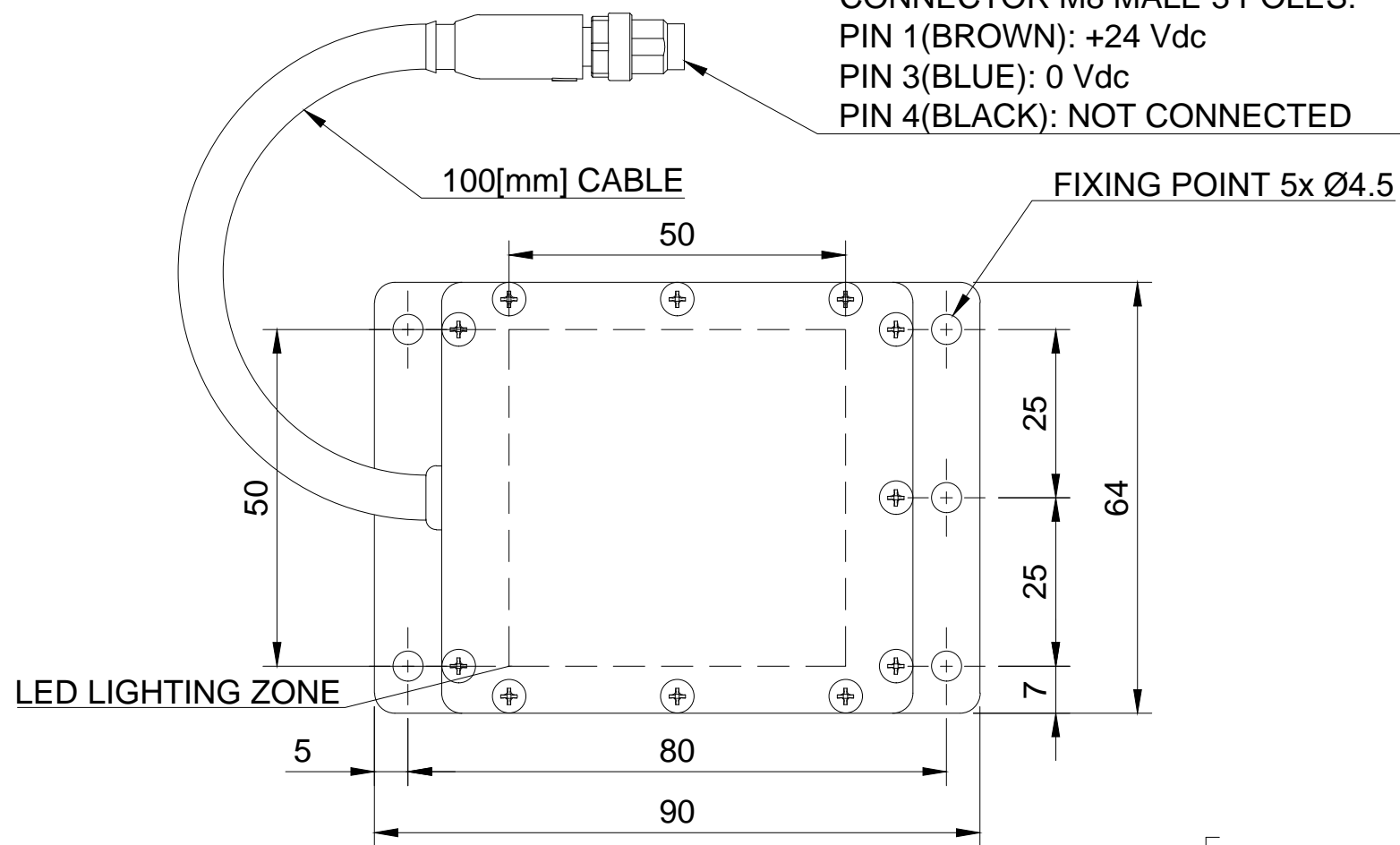

Undimensioned chamfers 0.5x45°

PAY ATTENTION:

install the illuminator so that the bottom wall is in direct contact with a flat metal surface. In this way the support surface of the illuminator will be able to guarantee an adequate dissipation of the heat produced by the LEDs. Maintaining a low illuminator temperature allows the average life of the LEDs to be lengthened and the light emission to remain stable.

Rev.	Description	Date	Sig.

General machining tolerances: H11 hole - h11 shaft - linear dimensions ±0.1mm - angular values ±30' Surface texture according to UNI 4600-83, unless otherwise specified. Geometrical tolerances according to UNI 7226-1.			
	Product	Initial revision date (0)	Group
	DL2	11/06/2026	--
Material	Scale	Designer	View
---	1:1	LSR	
Treatment	Quantity	Format	
---	1	A3	
Description	Drawing number	Table N/N	
DL2-50x50	---	1/1	
<small>Property of RODER s.r.l. - Via Aldo Moro 15A - 10080 - Oglianico (TO) - ITALY - Copyright by RODER s.r.l. - All rights reserved. Without written authorization from RODER s.r.l., this drawing may not be used for the manufacturing of the object represented herein, nor disclosed to third parties. The owner company will protect its rights to the full extent of the law. Unauthorized use of the content of this document constitutes a criminal and civil offense.</small>			